

Write your name here

Surname

Other names

Pearson Edexcel
Level 3 GCE

Centre Number

--	--	--	--	--

Candidate Number

--	--	--	--

Physics

Advanced

Paper 1: Advanced Physics I

Monday 4 June 2018 – Afternoon

Time: 1 hour 45 minutes

Paper Reference

9PH0/01

You must have:

Ruler

Total Marks

Instructions

- Use **black** ink or ball-point pen.
- **Fill in the boxes** at the top of this page with your name, centre number and candidate number.
- Answer **all** questions.
- Answer the questions in the spaces provided
– *there may be more space than you need.*

Information

- The total mark for this paper is 90.
- The marks for **each** question are shown in brackets
– *use this as a guide as to how much time to spend on each question.*
- You may use a scientific calculator.
- In questions marked with an **asterisk** (*), marks will be awarded for your ability to structure your answer logically showing how the points that you make are related or follow on from each other where appropriate.

Advice

- Read each question carefully before you start to answer it.
- Try to answer every question.
- Check your answers if you have time at the end.
- You are advised to show your working in calculations including units where appropriate.

Turn over ►

P52319A

©2018 Pearson Education Ltd.

1/1/1/1/





Pearson

Answer ALL questions.

All multiple choice questions must be answered with a cross \boxtimes in the box for the correct answer from A to D. If you change your mind about an answer, put a line through the box \boxtimes and then mark your new answer with a cross \boxtimes .

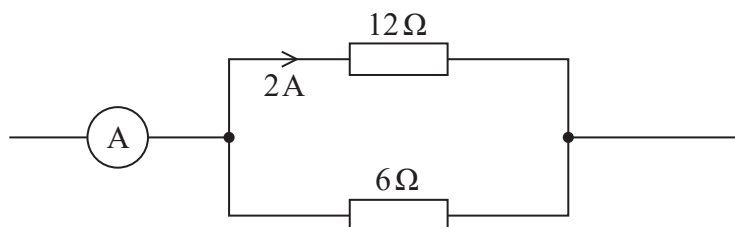
1 Part of an electric circuit is shown.



What is the current shown by the ammeter?

- A 3 A
- B 4 A
- C 5 A
- D 6 A

(Total for Question 1 = 1 mark)

2 A cell is connected across a resistor. After a while the internal resistance of the cell increases.

Which row of the table correctly shows the change in the current in the circuit and the change in the terminal potential difference across the cell?

	Current	Terminal potential difference
<input type="checkbox"/> A	decreases	decreases
<input type="checkbox"/> B	decreases	increases
<input type="checkbox"/> C	increases	decreases
<input type="checkbox"/> D	increases	increases

(Total for Question 2 = 1 mark)

DO NOT WRITE IN THIS AREA

DO NOT WRITE IN THIS AREA

DO NOT WRITE IN THIS AREA



3 An object is falling at terminal velocity.

Which of the following is **not** a valid conclusion from this statement?

- A The acceleration of the object is zero.
- B There is a resistive force acting on the object.
- C There is a resultant force acting on the object.
- D The object has weight.

(Total for Question 3 = 1 mark)

4 A light dependent resistor is connected across a cell of negligible internal resistance. The light intensity is increased.

Which of the following statements about the current is correct?

- A It decreases because there is an increase in the number of conduction electrons.
- B It increases because there is an increase in the number of conduction electrons.
- C It decreases because the amplitude of lattice vibrations decreases.
- D It increases because the amplitude of lattice vibrations increases.

(Total for Question 4 = 1 mark)

5 Which of the following graphs shows how the current varies with potential difference for a filament lamp?

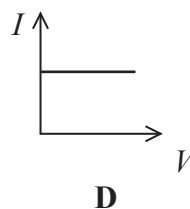
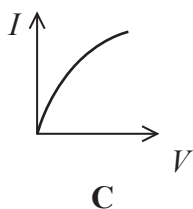
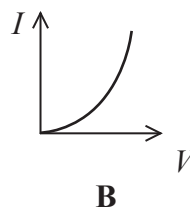
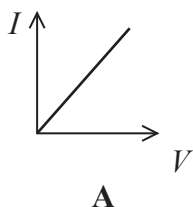

- A
- B
- C
- D

(Total for Question 5 = 1 mark)



6 Which of the following are the base units for impulse?

- A kg m s^{-1}
- B kg m s^{-2}
- C Nm
- D Ns

(Total for Question 6 = 1 mark)

7 A potential difference V is applied across two parallel plates. An electron midway between the two plates at point X experiences an electric force F .

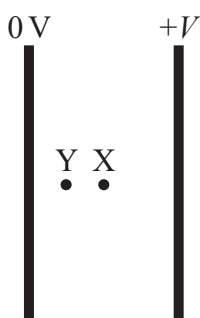

The electron moves to point Y which is halfway between point X and the left-hand plate.

Which of the following is the electric force experienced by the electron at Y?

- A $2F$
- B F
- C $\frac{F}{2}$
- D $\frac{F}{4}$

(Total for Question 7 = 1 mark)

8 A wire carries an alternating current of peak value 3 A.

Which of the following is the root-mean-square value of this current?

- A 1.5 A
- B 2.1 A
- C 4.2 A
- D 9.0 A

(Total for Question 8 = 1 mark)



9 Electric and magnetic fields can be used in particle accelerators.

Which row in the table correctly describes the use of electric and magnetic fields in the particle accelerator indicated?

	Particle accelerator	Magnetic field	Electric field
<input type="checkbox"/> A	cyclotron	not used	used to accelerate particles
<input type="checkbox"/> B	cyclotron	used to accelerate particles	used to accelerate particles
<input type="checkbox"/> C	linac	used to accelerate particles	not used
<input type="checkbox"/> D	linac	used to accelerate particles	used to accelerate particles

(Total for Question 9 = 1 mark)

10 Which of the following particle equations is correct for the decay of a proton within a nucleus?

- A $p \rightarrow n + \beta^+$
- B $p \rightarrow p + \beta^+$
- C $p \rightarrow n + \beta^+ + \nu$
- D $p \rightarrow p + \beta^+ + \nu$

(Total for Question 10 = 1 mark)



11 A “metre bridge” is a circuit which can be used to measure an unknown resistance accurately. The metre bridge includes a metre length of nichrome wire.

(a) Calculate the resistance of a 1.00 m length of the nichrome wire.

(3)

resistivity of nichrome = $1.12 \times 10^{-6} \Omega\text{m}$

diameter of wire = $4.00 \times 10^{-4} \text{ m}$

Resistance =

(b) This metre length of wire, labelled AB, is connected to a 1.50 V cell of negligible internal resistance and a switch as shown.

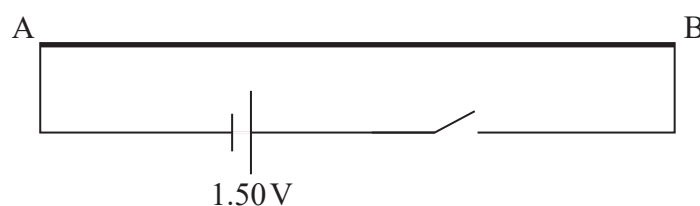

(i) Explain how the potential along this wire varies with distance from A when the switch is closed.

(2)

(ii) Show that the potential difference between A and a point 75.0 cm along the wire from A is about 1.1 V.

(2)



DO NOT WRITE IN THIS AREA

DO NOT WRITE IN THIS AREA

DO NOT WRITE IN THIS AREA

(c) The metre bridge circuit is shown. The circuit includes a resistor of resistance $3.30\ \Omega$, a very sensitive ammeter and a resistor of unknown resistance R .

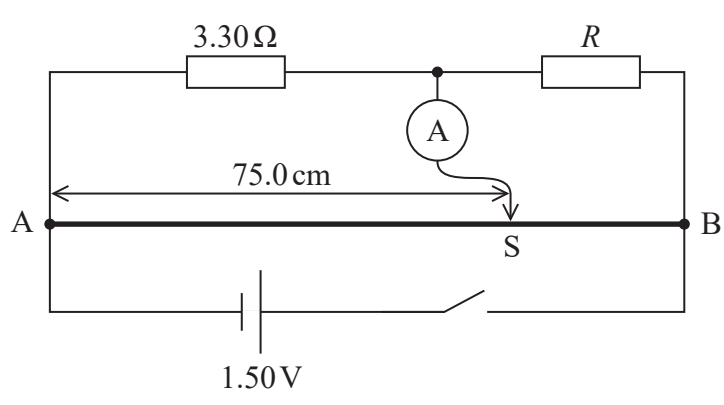

A metal slider S can be moved along the nichrome wire and pressed firmly against it to make an electrical connection.

When the switch is closed and S is 75.0 cm along the nichrome wire, the ammeter reads 0 A because the potential difference across the ammeter is zero.

Calculate R .

(2)

.....

.....

.....

.....

.....

$R =$

(Total for Question 11 = 9 marks)



*12 A simple electric motor consists of a coil that is free to rotate in a magnetic field.

A student connects the motor to an ammeter and a battery.

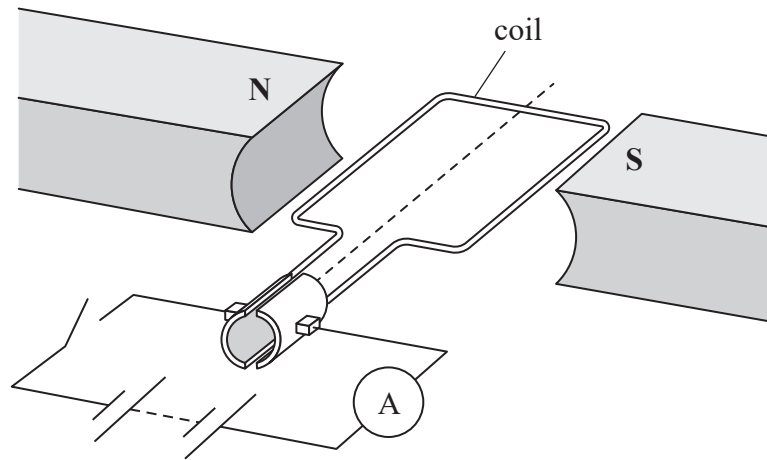

The graph shows how the current I in the coil varies with time t . The switch is closed at time T .

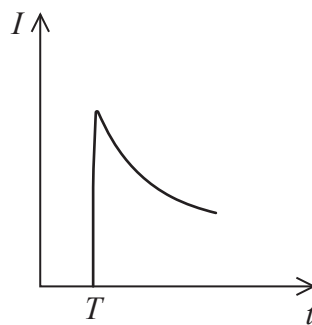

Explain why the current rises to a maximum then decreases.
Your answer should include a reference to Faraday and Lenz's laws.

(6)



DO NOT WRITE IN THIS AREA

DO NOT WRITE IN THIS AREA

DO NOT WRITE IN THIS AREA

(Total for Question 12 = 6 marks)



- 13 Beam engines contributed to powering the Industrial Revolution in Britain in the 18th century. A beam engine consisted of a beam which could rock to and fro around a well-oiled pivot. Attached to the beam there are two rods, one connected to a piston in a steam cylinder and the other connected to a pump.

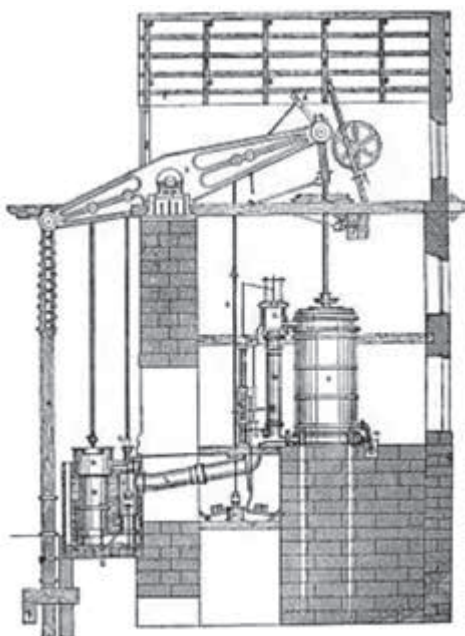

The diagram below shows a simplified arrangement of a beam engine.

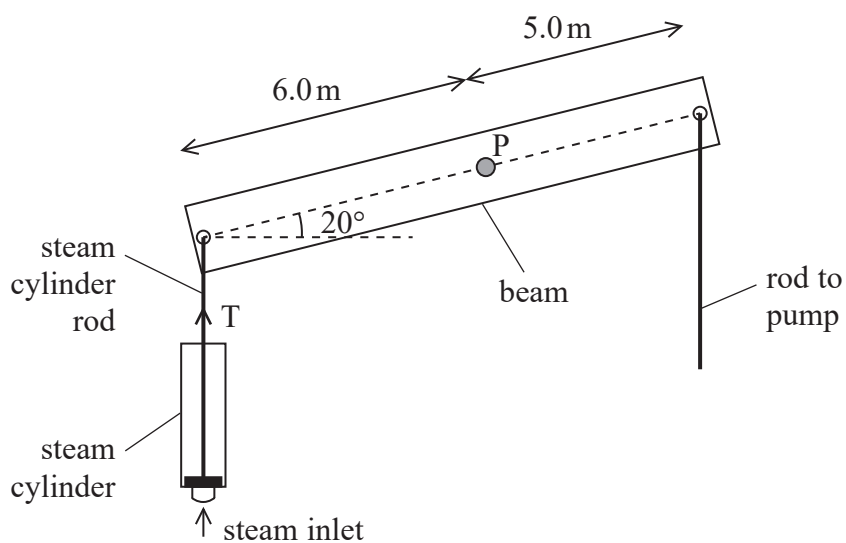

- (a) The beam has a constant thickness and a mass of 3.05×10^4 kg. The length of the beam is 11.0 m. The pivot P is positioned 6.0 m from the steam cylinder end of the beam.

In its resting position the steam cylinder rod is supported by the base of the steam cylinder with the beam at an angle of 20° to the horizontal.



The steam cylinder rod exerts a force T on the beam. The force exerted on the beam by the pump rod can be neglected.

Calculate the force T .

(4)

$T = \dots\dots\dots$

(b) The engine, which ran continuously, could lift a mass of 2500 kg of water through 12 m each minute.

The engine used 1250 kg of coal a day. 1 kg of coal can release 22.3 MJ of energy. The beam engine was said to have an efficiency of 10 %.

Deduce whether this claim for efficiency was correct.

(5)

(Total for Question 13 = 9 marks)

DO NOT WRITE IN THIS AREA

DO NOT WRITE IN THIS AREA

DO NOT WRITE IN THIS AREA



P 5 2 3 1 9 A 0 1 1 2 8

- 14 A physics class made a toy rocket. A drinks bottle was partially filled with water and inverted over a valve. An air pump delivered air to the bottle until the pressure forced the bottle from the valve and the water was ejected from the bottle at high speed.



A velocity-time graph for the bottle for the first 4 s after take-off is shown.

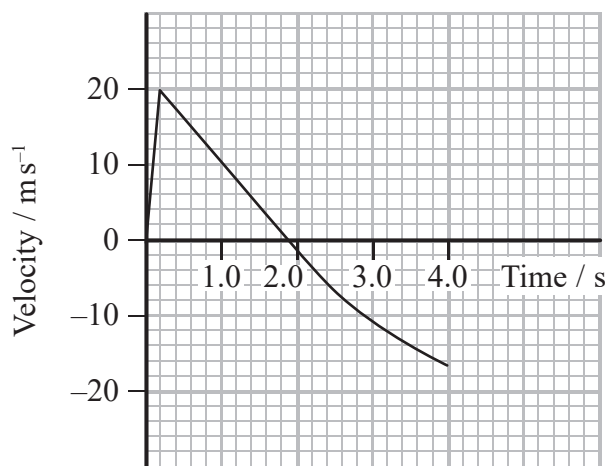

- (a) Determine the height to which the rocket travelled.

(2)

.....

.....

.....

.....

.....

.....

Height =



DO NOT WRITE IN THIS AREA

DO NOT WRITE IN THIS AREA

DO NOT WRITE IN THIS AREA

(b) Sketch the corresponding acceleration-time graph on the axes below.

(5)

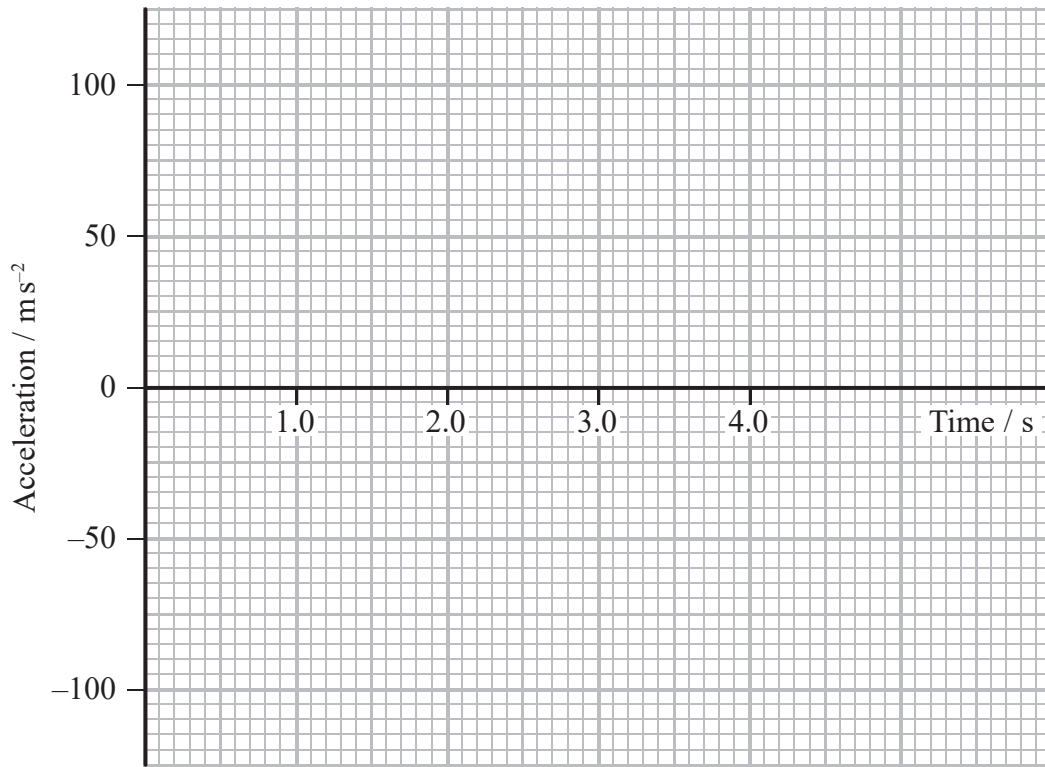

(Total for Question 14 = 7 marks)



P 5 2 3 1 9 A 0 1 3 2 8

DO NOT WRITE IN THIS AREA

DO NOT WRITE IN THIS AREA

DO NOT WRITE IN THIS AREA

BLANK PAGE



DO NOT WRITE IN THIS AREA

DO NOT WRITE IN THIS AREA

DO NOT WRITE IN THIS AREA

15 The discovery of the Higgs particle was an important contribution to our understanding of particle physics.

(a) Describe the standard model for subatomic particles. You should identify the fundamental particles and the composition of the particles we can observe. (5)

.....

.....

.....

.....

.....

.....

.....

.....

.....

.....

.....

.....

.....

.....

.....

.....

.....

.....

.....

.....

.....

.....

.....

(b) The mass of the Higgs particle is 2.2×10^{-25} kg.
Calculate this mass in GeV/c². (3)

.....

.....

.....

.....

.....

.....

.....

.....

.....

.....

Mass = GeV/c²



(c) The Higgs particle was discovered using the Large Hadron Collider (LHC) in 2012. Two beams of very high energy protons, moving in opposite directions, were made to collide.

(i) Explain the need for such high energy collisions.

(3)

.....

.....

.....

.....

.....

.....

(ii) The beams of protons are contained within a ring of superconducting magnets.

Calculate the momentum of a proton in a beam.

(3)

magnetic field strength = 8.3 T
circumference of the ring = 27 km

.....

.....

.....

.....

.....

Momentum =

(iii) State the total momentum of the products of the collision between the two beams of protons.

(1)

Total momentum =



(d) The LHC accelerates protons until they gain energies of about 7 TeV.

A student used the equation $E_k = \frac{p^2}{2m}$ to predict the energy of a proton in the beam, using the momentum calculated in (c)(ii), but found the energy was far higher than 7 TeV.

Explain why.

(2)

(Total for Question 15 = 17 marks)



16 (a) Sketch the electric field around a positive point charge.

(3)



DO NOT WRITE IN THIS AREA

DO NOT WRITE IN THIS AREA

DO NOT WRITE IN THIS AREA

(b) The graph shows how potential varies with distance from the centre of a charged sphere.

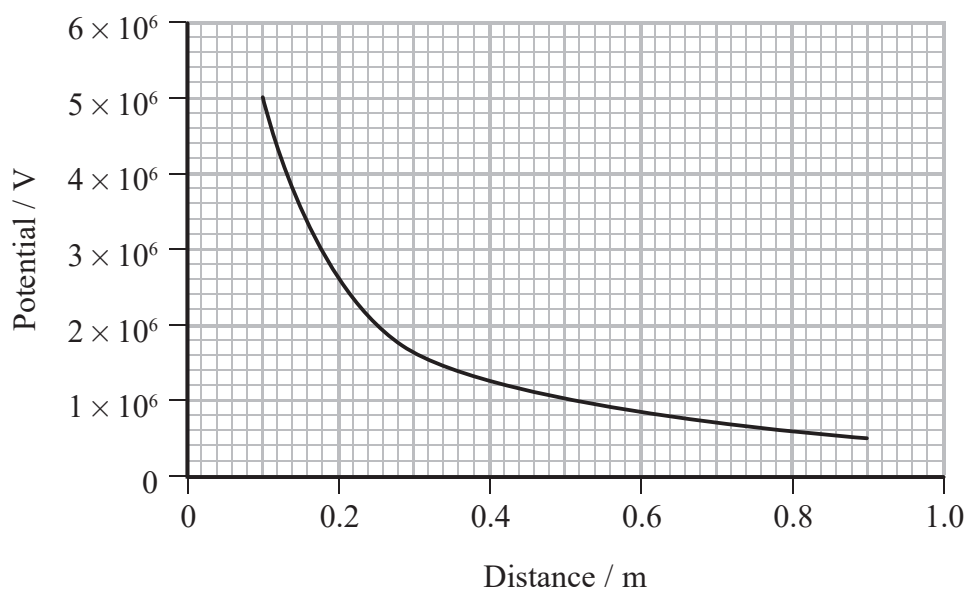

Air molecules will be ionised if the electric field strength exceeds $3 \times 10^6 \text{ V m}^{-1}$.

Deduce whether air molecules will be ionised at a distance of 30 cm from the centre of this sphere.

(4)

.....

.....

.....

.....

.....

.....



(c) A magician did a trick which he claimed was the most dangerous ever. He positioned himself midway between two charged spheres which were separated by a distance of about two metres. Each sphere was charged to a potential that would cause ionisation at a distance of one metre. He wore a protective suit of chain mail and a helmet consisting of a metal cage. The protective suit and helmet were earthed to a potential of 0 V.



A scientist said “there is no danger in this and I would happily do it tomorrow”.

Explain whether this statement is justified.

(3)

.....

.....

.....

.....

.....

.....

.....

.....

(Total for Question 16 = 10 marks)



17 A centrifuge is a machine which rotates.

(a) A particle in a centrifuge moves in a circle of radius r , centre O, with a constant speed v .

The diagram represents two positions of the particle.

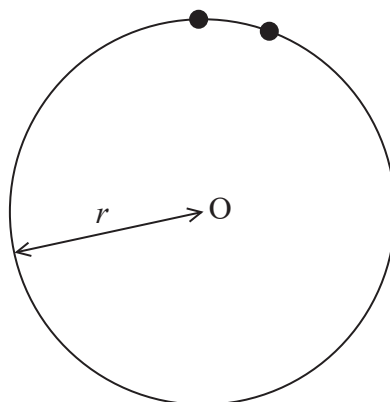

Derive the equation for centripetal acceleration $a = \frac{v^2}{r}$ by considering the velocity at these two positions.

Your answer should include a vector diagram.

(5)

.....

.....

.....

.....

.....

.....

.....

.....

.....

.....

.....

.....

.....

.....

.....

.....

.....

.....

.....

.....

.....

.....



DO NOT WRITE IN THIS AREA

DO NOT WRITE IN THIS AREA

DO NOT WRITE IN THIS AREA

- (b) The United States' space agency, NASA, uses a centrifuge to test whether equipment will operate when experiencing large forces. The equipment to be tested is attached to the end of the frame of the centrifuge, which rotates around a vertical axis at its centre.

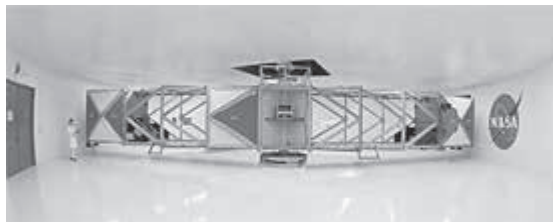

The centrifuge rotates at 50 revolutions per minute with a radius of 8.8 m.

- (i) Show that the angular velocity of the centrifuge is about 5 rad s^{-1} . (2)

.....

.....

.....

.....

- (ii) Explain how the centrifuge applies large forces to the equipment under test. (2)

.....

.....

.....

.....

- (iii) The NASA website says the centrifuge can be used to test whether the equipment can withstand accelerations of up to about $25g$.
Deduce whether this claim is correct. (2)

.....

.....

.....

.....

(Total for Question 17 = 11 marks)



18 A 'Gauss gun' can be made from five ball bearings of equal mass and two magnets, as shown.



Pairs of ball bearings are placed to the right of two strong magnets. A single ball bearing is released from the left, as shown. The ball bearing is attracted to, and collides with, the first magnet. This and all subsequent collisions can be assumed to be elastic.

- (a) Explain what happens to make the last ball bearing on the right subsequently move off with a large velocity.

(3)

.....

.....

.....

.....

.....

.....

.....

.....

.....

DO NOT WRITE IN THIS AREA

DO NOT WRITE IN THIS AREA

DO NOT WRITE IN THIS AREA



(b) A student set up the apparatus shown to measure the speed of the last ball bearing. The 'Gauss gun' was placed at the end of a bench, so that the ball bearing left the gun and broke two strips of metal foil which formed part of an electric circuit.

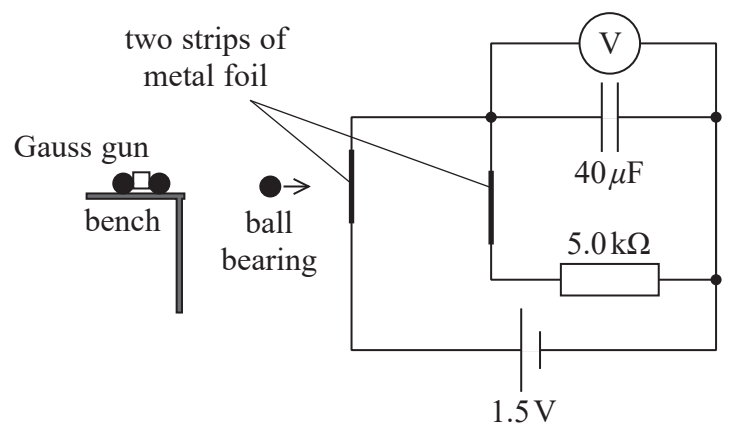

As the ball bearing left the gun, it broke the first foil strip at its centre so that the capacitor started to discharge. When the ball bearing broke the second foil strip the capacitor discharge stopped.

(i) Calculate the energy stored in the capacitor when it was fully charged. (2)

.....

.....

.....

.....

Energy stored =

(ii) The voltmeter reading halved in the time taken for the ball bearing to travel between the two foil strips.

Show that the time taken for the ball bearing to travel between the two foil strips was about 0.1 s.

(2)

.....

.....

.....

.....



(iii) The two foil strips were 0.50 m apart.

Calculate the horizontal velocity of the ball bearing.

(2)

.....

.....

.....

.....

Horizontal velocity =

(iv) The student positioned the second foil strip with its centre 8.0 cm lower than the centre of the first foil strip.

Deduce whether the ball bearing broke the second foil strip at its centre.

Assume the ball bearing was travelling horizontally as it broke the first foil strip.

(2)

.....

.....

.....

.....

.....

.....

.....

(Total for Question 18 = 11 marks)

TOTAL FOR PAPER = 90 MARKS

DO NOT WRITE IN THIS AREA

DO NOT WRITE IN THIS AREA

DO NOT WRITE IN THIS AREA



List of data, formulae and relationships

Acceleration of free fall	$g = 9.81 \text{ m s}^{-2}$	(close to Earth's surface)
Boltzmann constant	$k = 1.38 \times 10^{-23} \text{ J K}^{-1}$	
Coulomb law constant	$k = \frac{1}{4\pi\epsilon_0} = 8.99 \times 10^9 \text{ N m}^2 \text{ C}^{-2}$	
Electron charge	$e = -1.60 \times 10^{-19} \text{ C}$	
Electron mass	$m_e = 9.11 \times 10^{-31} \text{ kg}$	
Electronvolt	$1 \text{ eV} = 1.60 \times 10^{-19} \text{ J}$	
Gravitational constant	$G = 6.67 \times 10^{-11} \text{ N m}^2 \text{ kg}^{-2}$	
Gravitational field strength	$g = 9.81 \text{ N kg}^{-1}$	(close to Earth's surface)
Permittivity of free space	$\epsilon_0 = 8.85 \times 10^{-12} \text{ F m}^{-1}$	
Planck constant	$h = 6.63 \times 10^{-34} \text{ J s}$	
Proton mass	$m_p = 1.67 \times 10^{-27} \text{ kg}$	
Speed of light in a vacuum	$c = 3.00 \times 10^8 \text{ m s}^{-1}$	
Stefan-Boltzmann constant	$\sigma = 5.67 \times 10^{-8} \text{ W m}^{-2} \text{ K}^{-4}$	
Unified atomic mass unit	$u = 1.66 \times 10^{-27} \text{ kg}$	

Mechanics

Work, energy and power

Kinematic equations of motion

$$s = \frac{(u + v)t}{2}$$

$$v = u + at$$

$$s = ut + \frac{1}{2}at^2$$

$$v^2 = u^2 + 2as$$

$$\Delta W = F\Delta s$$

$$E_k = \frac{1}{2}mv^2$$

$$\Delta E_{\text{grav}} = mg\Delta h$$

$$P = \frac{E}{t}$$

$$P = \frac{W}{t}$$

Forces

$$\Sigma F = ma$$

$$g = \frac{F}{m}$$

$$W = mg$$

$$\text{moment of force} = Fx$$

$$\text{efficiency} = \frac{\text{useful energy output}}{\text{total energy input}}$$

$$\text{efficiency} = \frac{\text{useful power output}}{\text{total power input}}$$

Momentum

$$p = mv$$



Electric circuits

Potential difference

$$V = \frac{W}{Q}$$

Resistance

$$R = \frac{V}{I}$$

Electrical power and energy

$$P = VI$$

$$P = I^2R$$

$$P = \frac{V^2}{R}$$

$$W = VIt$$

Resistivity

$$R = \frac{\rho l}{A}$$

Current

$$I = \frac{\Delta Q}{\Delta t}$$

$$I = nqvA$$

Materials

Density

$$\rho = \frac{m}{V}$$

Stokes' law

$$F = 6\pi\eta r v$$

Hooke's law

$$\Delta F = k\Delta x$$

Young modulus

$$\text{Stress } \sigma = \frac{F}{A}$$

$$\text{Strain } \varepsilon = \frac{\Delta x}{x}$$

$$E = \frac{\sigma}{\varepsilon}$$

Elastic strain energy

$$\Delta E_{\text{el}} = \frac{1}{2}F\Delta x$$

Waves and Particle Nature of Light

Wave speed

$$v = f\lambda$$

Speed of a transverse wave on a string

$$v = \sqrt{\frac{T}{\mu}}$$

Intensity of radiation

$$I = \frac{P}{A}$$

Power of a lens

$$P = \frac{1}{f}$$

$$P = P_1 + P_2 + P_3 + \dots$$

Thin lens equation

$$\frac{1}{u} + \frac{1}{v} = \frac{1}{f}$$

Magnification for a lens

$$m = \frac{\text{image height}}{\text{object height}} = \frac{v}{u}$$

Diffraction grating

$$n\lambda = d \sin \theta$$



Refractive index

$$n_1 \sin \theta_1 = n_2 \sin \theta_2$$

$$n = \frac{c}{v}$$

Critical angle

$$\sin C = \frac{1}{n}$$

Photon model

$$E = hf$$

Einstein's photoelectric equation

$$hf = \phi + \frac{1}{2}mv_{\max}^2$$

de Broglie wavelength

$$\lambda = \frac{h}{p}$$

Further mechanics

Impulse

$$F\Delta t = \Delta p$$

Kinetic energy of a non-relativistic particle

$$E_k = \frac{p^2}{2m}$$

Motion in a circle

$$v = \omega r$$

$$T = \frac{2\pi}{\omega}$$

$$F = ma = \frac{mv^2}{r}$$

$$a = \frac{v^2}{r}$$

$$a = r\omega^2$$

Centripetal force

$$F = \frac{mv^2}{r}$$

$$F = mr\omega^2$$

Fields

Coulomb's law

$$F = k \frac{Q_1 Q_2}{r^2}$$

$$\text{where } k = \frac{1}{4\pi\epsilon_0}$$

Electric field strength

$$E = \frac{F}{Q}$$

$$E = k \frac{Q}{r^2}$$

$$E = \frac{V}{d}$$

Electric potential

$$V = k \frac{Q}{r}$$

Capacitance

$$C = \frac{Q}{V}$$

Energy stored in a capacitor

$$W = \frac{1}{2}QV$$

Capacitor discharge

$$Q = Q_0 e^{-t/RC}$$

Resistor – capacitor discharge

$$I = I_0 e^{-t/RC}$$

$$V = V_0 e^{-t/RC}$$

In a magnetic field

$$F = BIl \sin \theta$$

$$F = Bqv \sin \theta$$

Faraday's and Lenz's laws

$$\mathcal{E} = \frac{-d(N\phi)}{dt}$$

Root-mean-square values

$$V_{\text{rms}} = \frac{V_0}{\sqrt{2}}$$

$$I_{\text{rms}} = \frac{I_0}{\sqrt{2}}$$



Nuclear and particle physics

In a magnetic field

$$r = \frac{p}{BQ}$$

Thermodynamics

Heating

$$\Delta E = mc\Delta\theta$$

$$\Delta E = L\Delta m$$

Molecular kinetic theory

$$\frac{1}{2}m\langle c^2 \rangle = \frac{3}{2}kT$$

$$pV = \frac{1}{3}Nm\langle c^2 \rangle$$

Ideal gas equation

$$pV = NkT$$

Stefan-Boltzmann law

$$L = \sigma AT^4$$

$$L = \sigma 4\pi r^2 T^4$$

Wien's law

$$\lambda_{\max} T = 2.898 \times 10^{-3} \text{ m K}$$

Space

Intensity

$$I = \frac{L}{4\pi d^2}$$

Redshift of electromagnetic radiation

$$z = \frac{\Delta\lambda}{\lambda} \approx \frac{\Delta f}{f} \approx \frac{v}{c}$$

Cosmological expansion

$$v = H_0 d$$

Nuclear radiation

Mass-energy

$$\Delta E = c^2 \Delta m$$

Radioactive decay

$$A = \lambda N$$

$$\frac{dN}{dt} = -\lambda N$$

$$\lambda = \frac{\ln 2}{t_{1/2}}$$

$$N = N_0 e^{-\lambda t}$$

$$A = A_0 e^{-\lambda t}$$

Gravitational fields

Gravitational force

$$F = \frac{Gm_1 m_2}{r^2}$$

Gravitational field strength

$$g = \frac{Gm}{r^2}$$

Gravitational potential

$$V_{\text{grav}} = \frac{-Gm}{r}$$

Oscillations

Simple harmonic motion

$$F = -kx$$

$$a = -\omega^2 x$$

$$x = A \cos \omega t$$

$$v = -A\omega \sin \omega t$$

$$a = -A\omega^2 \cos \omega t$$

$$T = \frac{1}{f} = \frac{2\pi}{\omega}$$

$$\omega = 2\pi f$$

Simple harmonic oscillator

$$T = 2\pi \sqrt{\frac{m}{k}}$$

$$T = 2\pi \sqrt{\frac{l}{g}}$$

